

Improve Your Motions

FEKERMANTM

Locking Devices

Metric



FK-01

Ordering code sample
FK-01 dxD 19x47

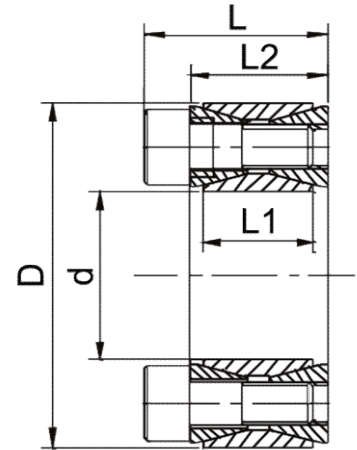

Size(mm)	Dimension (mm)			Rated Load		Surface Pressure		Tightening Screws	
	d x D	L1	L2	L	Axial KN	Torque N.m	Shaft N/mm2	Hub N/mm2	DIN912 12.9 N°x Type
19 x 47	17	20	26	31	298	286	116	8 x M6	14.9
20 x 47	17	20	26	31	313	272	116	8 x M6	14.9
22 x 47	17	20	26	31	345	247	116	8 x M6	14.9
24 x 50	17	20	26	35	424	255	123	9 x M6	14.9
25 x 50	17	20	26	35	441	245	123	9 x M6	14.9
28 x 55	17	20	26	39	549	243	124	10 x M6	14.9
30 x 55	17	20	26	39	588	227	124	10 x M6	14.9
32 x 60	17	20	26	47	752	255	136	12 x M6	14.9
35 x 60	17	20	26	47	822	233	136	12 x M6	14.9
38 x 65	17	20	26	55	1042	250	146	14 x M6	14.9
40 x 65	17	20	26	55	1097	238	146	14 x M6	14.9
42 x 75	20	24	32	83	1740	291	163	12 x M8	35
45 x 75	20	24	32	83	1864	271	163	12 x M8	35
48 x 80	20	24	32	83	1988	254	153	12 x M8	35
50 x 80	20	24	32	83	2071	244	153	12 x M8	35
55 x 85	20	24	32	97	2658	259	168	14 x M8	35
60 x 90	20	24	32	97	2900	238	158	14 x M8	35
65 x 95	20	24	32	110	3587	250	171	16 x M8	35
70 x 110	24	28	38	153	5345	268	171	14 x M10	69
75 x 115	24	28	38	153	5727	250	163	14 x M10	69
80 x 120	24	28	38	153	6108	235	156	14 x M10	69
85 x 125	24	28	38	175	7417	252	172	16 x M10	69
90 x 130	24	28	38	175	7854	238	165	16 x M10	69
95 x 135	24	28	38	196	9326	254	179	18 x M10	69
100 x 145	26	33	45	227	11362	258	178	14 x M12	123.3
110 x 155	26	33	45	227	12498	234	166	14 x M12	123.3
120 x 165	26	33	45	260	15578	245	178	16 x M12	123.3
130 x 180	34	38	50	325	21095	217	156	20 x M12	123.3

FK-01

Ordering code sample
FK-01 dxD 150x200

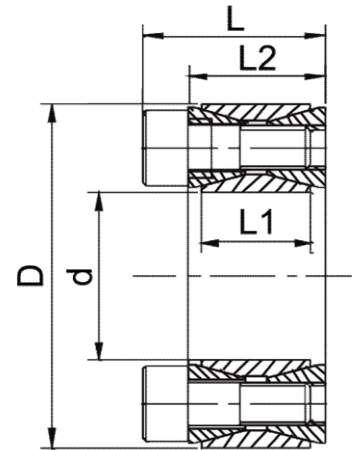

Size(mm)	Dimension (mm)			Rated Load		Surface Pressure		Tightening Screws	
	d x D	L1	L2	L	Axial KN	Torque N.m	Shaft N/mm ²	Hub N/mm ²	DIN912 12.9 N°x Type
140 x 190	34	38	50	357	24993	221	163	22 x M12	123.3
150 x 200	34	38	50	390	29217	225	169	24 x M12	123.3
160 x 210	34	38	50	422	33756	229	174	26 x M12	123.3
170 x 225	38	44	58	465	39483	212	160	22 x M14	187
180 x 235	38	44	58	507	45606	218	167	24 x M14	187
190 x 250	46	52	66	591	56163	199	152	28 x M14	187
200 x 260	46	52	66	633	63342	203	156	30 x M14	187
220 x 285	50	56	72	745	81960	200	154	26 x M16	290
240 x 305	50	56	72	860	103162	211	166	30 x M16	290
260 x 325	50	56	72	974	126669	221	177	34 x M16	290
280 x 355	60	66	84	1124	157339	197	156	32 x M18	400
300 x 375	60	66	84	1264	189653	207	166	36 x M18	400
320 x 405	72	78	98	1651	264108	211	167	36 x M20	580
340 x 425	72	78	98	1651	280614	199	159	36 x M20	580
360 x 455	84	90	112	2017	363061	197	156	36 x M22	780
380 x 475	84	90	112	2017	383232	186	149	36 x M22	780
400 x 495	84	90	112	2017	403402	177	143	36 x M22	780
420 x 515	84	90	112	2241	470633	187	153	40 x M22	780
440 x 545	96	102	126	2634	579506	184	148	40 x M24	1000
460 x 565	96	102	126	2634	605848	176	176	40 x M24	1000
480 x 585	96	102	126	2766	663811	177	177	42 x M24	1000
500 x 605	96	102	126	2898	724383	178	178	44 x M24	1000
520 x 630	96	102	126	2963	770487	175	175	45 x M24	1000
540 x 650	96	102	126	2963	800121	169	169	45 x M24	1000
560 x 670	96	102	126	3161	885064	173	173	48 x M24	1000
580 x 690	96	102	126	3293	954884	174	174	50 x M24	1000
600 x 710	96	102	126	3293	987811	169	169	50 x M24	1000

FK-02

Ordering code sample
FK-02 dxD 19x27

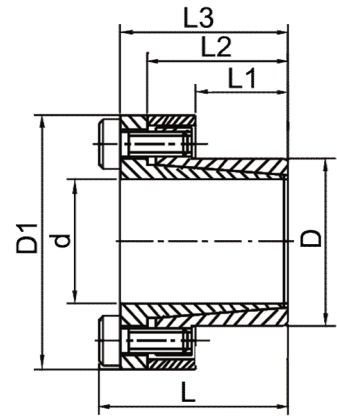

Size(mm)	Dimension (mm)					Rated Load		Surface Pressure		Tightening Screws	
	d x D	L1	L2	L3	L	D1	Axial KN	Torque N.m	Shaft N/mm2	Hub N/mm2	DIN912 12.9 N°x Type
19 x 27	18	31	38	44	48	21	202	183	129	4 x M6	17
20 x 28	18	31	38	44	49	21	213	174	124	4 x M6	17
22 x 32	25	38	45	51	54	21	234	114	78	4 x M6	17
24 x 34	25	38	45	51	56	21	255	105	74	4 x M6	17
25 x 34	25	38	45	51	56	21	266	100	74	4 x M6	17
28 x 39	25	38	45	51	61	27	373	112	81	5 x M6	17
30 x 41	25	38	45	51	63	32	480	126	92	6 x M6	17
32 x 43	30	43	50	56	65	32	511	98	73	6 x M6	17
35 x 47	30	43	50	56	69	43	747	120	89	8 x M6	17
38 x 50	30	43	50	56	72	43	811	110	84	8 x M6	17
40 x 53	32	45	52	58	75	48	959	110	83	9 x M6	17
42 x 55	32	45	52	58	77	48	1007	105	80	9 x M6	17
45 x 59	40	56	64	72	85	79	1781	130	99	8 x M8	42
48 x 62	40	56	64	72	88	79	1900	122	94	8 x M8	42
50 x 65	50	66	74	82	92	99	2473	117	90	10 x M8	42
55 x 71	50	66	74	82	98	99	2721	106	82	10 x M8	42
60 x 77	50	66	74	82	104	99	2968	97	76	10 x M8	42
65 x 84	50	66	74	82	111	99	3215	90	69	10 x M8	42
70 x 90	60	80	91	101	122	127	4430	89	69	8 x M10	84
75 x 95	60	80	91	101	126	142	5338	93	74	9 x M10	84
80 x 100	65	85	96	106	131	190	7595	108	86	12 x M10	84
85 x 106	65	85	96	106	137	190	8069	101	81	12 x M10	84
90 x 112	65	85	96	106	143	222	9968	112	90	14 x M10	84
95 x 120	65	85	96	106	153	222	10522	106	84	14 x M10	84
100 x 125	65	89	102	114	162	273	13651	124	99	12 x M12	145
110 x 140	70	94	107	119	177	273	15016	105	82	12 x M12	145
120 x 155	90	114	127	139	195	364	21844	99	77	16 x M12	145
130 x 165	90	114	127	139	205	364	23664	92	72	16 x M12	145
140 x 175	90	114	127	139	215	364	25485	85	68	16 x M12	145
150 x 185	90	114	127	139	225	364	27305	80	64	16 x M12	145

FK-03

Ordering code sample
FK-03 dxD 19x47

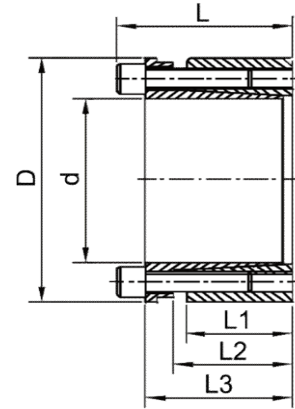

Size(mm)	Dimension (mm)				Rated Load		Surface Pressure		Tightening Screws	
	d x D	L1	L2	L3	L	Axial KN	Torque N.m	Shaft N/mm ²	Hub N/mm ²	DIN912 12.9 N°x Type
19 x 47	26	31	39	45	32	307	193	78	4 x M6	17
20 x 47	26	31	39	45	32	323	183	78	4 x M6	17
22 x 47	26	31	39	45	32	355	166	78	4 x M6	17
24 x 50	26	31	39	45	48	582	229	110	6 x M6	17
25 x 50	26	31	39	45	48	606	220	110	6 x M6	17
28 x 55	26	31	39	45	48	679	196	100	6 x M6	17
30 x 55	26	31	39	45	48	727	183	100	6 x M6	17
32 x 60	26	31	39	45	65	1033	229	122	8 x M6	17
35 x 60	26	31	39	45	65	1130	209	122	8 x M6	17
38 x 65	26	31	39	45	65	1227	193	113	8 x M6	17
40 x 65	26	31	39	45	65	1292	183	113	8 x M6	17
42 x 75	30	36	47	55	87	1835	204	115	6 x M8	41
45 x 75	30	36	47	55	87	1966	191	115	6 x M8	41
48 x 80	30	36	47	55	87	2097	179	107	6 x M8	41
50 x 80	30	36	47	55	87	2184	172	107	6 x M8	41
55 x 85	30	36	47	55	116	3202	208	135	8 x M8	41
60 x 90	30	36	47	55	116	3493	191	127	8 x M8	41
65 x 95	30	36	47	55	116	3784	176	120	8 x M8	41
70 x 110	40	46	57	67	189	6607	199	127	8 x M10	83
75 x 115	40	46	62	67	189	7079	186	121	8 x M10	83
80 x 120	40	46	62	72	189	7551	174	116	8 x M10	83
85 x 125	40	46	62	72	236	10029	205	139	10 x M10	83
90 x 130	40	46	62	72	236	10619	193	134	10 x M10	83
95 x 135	40	46	62	72	236	11209	183	129	10 x M10	83
100 x 145	46	52	77	89	275	13738	176	121	8 x M12	145
110 x 155	46	52	77	89	275	15111	160	114	8 x M12	145
120 x 165	46	52	77	89	343	20606	183	133	10 x M12	145
130 x 180	46	52	77	89	412	26788	203	147	12 x M12	145
140 x 190	51	59	84	98	373	26142	154	114	8 x M14	230

FK-03

Ordering code sample
FK-03 dxD 160x210

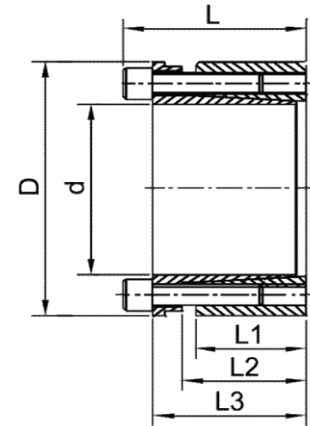

Size(mm)	Dimension (mm)				Rated Load		Surface Pressure		Tightening Screws	
	d x D	L1	L2	L3	L	Axial KN	Torque N.m	Shaft N/mm ²	Hub N/mm ²	DIN912 12.9 N°x Type
150 x 200	51	59	84	98	467	35016	180	135	10 x M14	230
160 x 210	51	59	84	98	467	37351	169	129	10 x M14	230
170 x 225	51	59	84	98	560	47617	191	144	12 x M14	230
180 x 235	51	59	84	98	560	50418	180	138	12 x M14	230
190 x 250	51	59	84	98	700	66526	213	162	15 x M14	230
200 x 260	51	59	84	98	700	70027	202	156	15 x M14	230
220 x 285	64	72	100	116	757	83243	158	122	12 x M16	355
240 x 305	64	72	100	116	946	113517	182	143	15 x M16	355
260 x 325	64	72	100	116	1135	147560	201	161	18 x M16	355
280 x 355	75	83	123	141	1226	171582	172	136	16 x M18	485
300 x 375	75	83	123	141	1379	206809	181	145	18 x M18	485
320 x 405	90	98	142	162	1766	282493	181	143	18 x M20	690
340 x 425	90	98	142	162	2060	350180	199	159	21 x M20	690
360 x 455	110	118	166	188	2164	389480	161	127	18 x M22	930
380 x 475	110	118	166	188	2524	479634	178	142	21 x M22	930
400 x 495	110	118	166	188	2524	504878	186	150	21 x M22	930

FK-04

Ordering code sample
FK-04 dxD 19x47

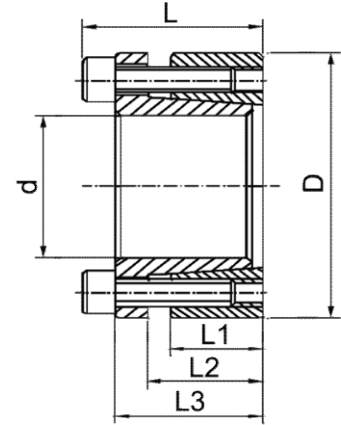

Size(mm)	Dimension (mm)				Rated Load		Surface Pressure		Tightening Screws	
	d x D	L1	L2	L3	L	Axial KN	Torque N.m	Shaft N/mm ²	Hub N/mm ²	DIN912 12.9 N°x Type
19 x 47	17	22	28	34	29	273	262	106	5 x M6	13
20 x 47	17	22	28	34	29	287	249	106	5 x M6	13
22 x 47	17	22	28	34	29	316	227	106	5 x M6	13
24 x 50	17	22	28	34	34	413	249	120	6 x M6	13
25 x 50	17	22	28	34	34	431	239	120	6 x M6	13
28 x 55	17	22	28	34	34	482	213	109	6 x M6	13
30 x 55	17	22	28	34	34	517	199	109	6 x M6	13
32 x 60	17	22	28	34	46	734	249	133	8 x M6	13
35 x 60	17	22	28	34	46	803	227	133	8 x M6	13
38 x 65	17	22	28	34	46	872	210	122	8 x M6	13
40 x 65	17	22	28	34	46	918	199	122	8 x M6	13
42 x 75	20	25	33	41	74	1563	261	146	7 x M8	32
45 x 75	20	25	33	41	74	1674	244	146	7 x M8	32
50 x 80	20	25	33	41	74	1860	219	137	7 x M8	32
55 x 85	20	25	33	41	85	2340	228	148	8 x M8	32
60 x 90	20	25	33	41	85	2553	209	139	8 x M8	32
65 x 95	20	25	33	41	96	3110	217	149	9 x M8	32
70 x 110	24	30	40	50	138	4838	243	154	8 x M10	36
75 x 115	24	30	40	50	138	5184	226	148	8 x M10	36
80 x 120	24	30	40	50	138	5530	212	142	8 x M10	36
85 x 125	24	30	40	50	156	6610	225	153	9 x M10	36
90 x 130	24	30	40	50	156	6998	212	147	9 x M10	36
95 x 135	24	30	40	50	173	8208	223	157	10 x M10	36
100 x 145	26	32	44	56	195	9742	221	152	8 x M12	110
110 x 155	26	32	44	56	195	10716	201	143	8 x M12	110
120 x 165	26	32	44	56	219	13154	207	151	9 x M12	110
130 x 180	34	40	52	64	292	18996	195	141	12 x M12	110
140 x 190	34	40	52	64	291	20336	180	133	9 x M14	170
150 x 200	34	40	52	64	323	24211	187	140	10 x M14	170

FK-04

Ordering code sample
FK-04 dxD 160x210

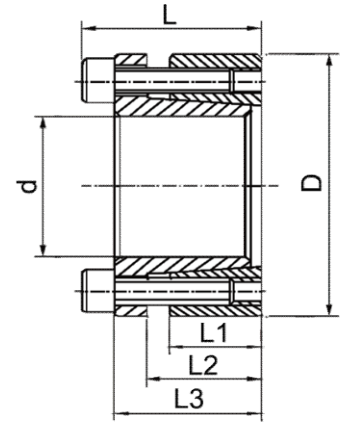

Size(mm)	Dimension (mm)				Rated Load		Surface Pressure		Tightening Screws	
	d x D	L1	L2	L3	L	Axial KN	Torque N.m	Shaft N/mm ²	Hub N/mm ²	DIN912 12.9 N°x Type
160 x 210	34	40	54	68	355	28408	192	147	11 x M14	170
170 x 225	44	50	64	78	387	32929	153	115	12 x M14	170
180 x 235	44	50	64	78	387	34866	144	110	12 x M14	170
190 x 250	44	50	64	78	484	45996	171	130	15 x M14	170
200 x 260	44	50	64	78	484	48416	162	125	15 x M14	170
220 x 285	50	56	75	91	548	60291	147	113	12 x M16	275
240 x 305	50	56	75	91	685	82218	168	132	15 x M16	275
260 x 325	50	56	75	91	731	95009	166	133	16 x M16	275
280 x 355	60	66	87	105	910	127341	160	126	16 x M18	385
300 x 375	60	66	87	105	1023	153479	168	134	18 x M18	385
320 x 405	74	81	101	121	1388	222065	140	110	18 x M20	580
340 x 425	74	81	101	121	1619	275271	153	123	21 x M20	580
360 x 455	86	94	116	138	1697	305480	131	104	18 x M22	780
380 x 475	86	94	116	138	1980	376193	145	116	21 x M22	780
400 x 495	86	94	116	138	1980	395993	137	111	21 x M22	780

FK-05

Ordering code sample
FK-05 dxD 19x47

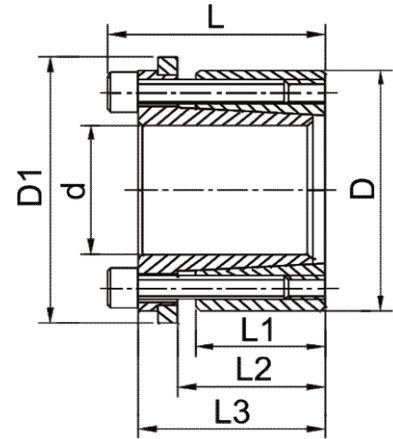

Size(mm)	Dimension (mm)					Rated Load		Surface Pressure		Tightening Screws	
	d x D	L1	L2	L3	L	D1	Axial KN	Torque N.m	Shaft N/mm2	Hub N/mm2	DIN912 12.9 N°x Type
19 x 47	26	31	39	45	53	21	202	127	51	4 x M6	17
20 x 47	26	31	39	45	53	21	213	121	51	4 x M6	17
22 x 47	26	31	39	45	53	21	234	110	51	4 x M6	17
24 x 50	26	31	39	45	56	32	384	151	73	6 x M6	17
25 x 50	26	31	39	45	56	32	400	145	73	6 x M6	17
28 x 55	26	31	39	45	61	32	448	129	66	6 x M6	17
30 x 55	26	31	39	45	61	32	480	121	66	6 x M6	17
32 x 60	26	31	39	45	66	43	683	151	81	8 x M6	17
35 x 60	26	31	39	45	66	43	747	138	81	8 x M6	17
38 x 65	26	31	39	45	71	43	811	127	74	8 x M6	17
40 x 65	26	31	39	45	71	43	853	121	74	8 x M6	17
42 x 75	30	36	47	55	81	58	1216	135	76	6 x M8	41
45 x 75	30	36	47	55	81	58	1302	126	76	6 x M8	41
48 x 80	30	36	47	55	86	58	1389	119	71	6 x M8	41
50 x 80	30	36	47	55	86	58	1447	114	71	6 x M8	41
55 x 85	30	36	47	55	91	77	2124	138	89	8 x M8	41
60 x 90	30	36	47	55	96	77	2317	127	84	8 x M8	41
65 x 95	30	36	47	55	101	77	2510	117	80	8 x M8	41
70 x 110	40	46	62	72	116	125	4381	132	84	8 x M10	83
75 x 115	40	46	62	72	121	125	4694	123	80	8 x M10	83
80 x 120	40	46	62	72	126	125	5007	115	77	8 x M10	83
85 x 125	40	46	62	72	131	156	6651	136	92	10 x M10	83
90 x 130	40	46	62	72	136	156	7042	128	89	10 x M10	83
95 x 135	40	46	62	72	141	156	7433	121	85	10 x M10	83
100 x 145	46	52	77	89	151	182	9104	117	81	8 x M12	145
110 x 155	46	52	77	89	161	182	10015	106	75	8 x M12	145
120 x 165	46	52	77	89	171	228	13653	122	88	10 x M12	145
130 x 180	46	52	77	89	186	273	17747	135	97	12 x M12	145

FK-05

Ordering code sample
FK-05 dxD 160x210

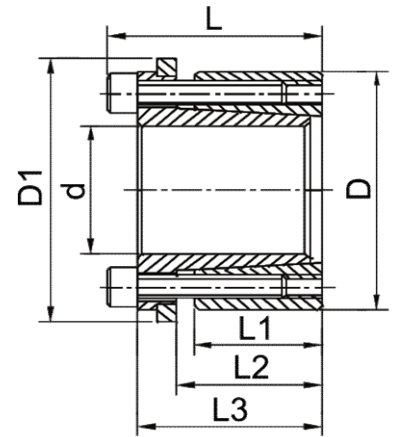

Size(mm)	Dimension (mm)					Rated Load		Surface Pressure		Tightening Screws	
	d x D	L1	L2	L3	L	D1	Axial KN	Torque N.m	Shaft N/mm2	Hub N/mm2	DIN912 12.9 N°x Type
140 x 190	51	59	84	98	196	248	17328	102	75	8 x M14	230
150 x 200	51	59	84	98	206	309	23207	119	89	10 x M14	230
160 x 210	51	59	84	98	216	309	24754	112	85	10 x M14	230
170 x 225	51	59	84	98	231	371	31561	126	95	12 x M14	230
180 x 235	51	59	84	98	241	371	33417	119	91	12 x M14	230
190 x 250	51	59	84	98	256	464	44097	141	107	15 x M14	230
200 x 260	51	59	84	98	266	461	46418	134	103	15 x M14	230
220 x 285	64	72	100	116	291	501	55147	105	81	12 x M16	355
240 x 305	64	72	100	116	311	627	75207	120	95	15 x M16	355
260 x 325	64	72	100	116	331	752	97775	133	107	18 x M16	355
280 x 355	75	83	123	141	361	812	113657	114	90	16 x M18	485
300 x 375	75	83	123	141	381	913	136987	120	96	18 x M18	485
320 x 405	90	98	142	162	411	1170	187177	120	95	18 x M20	690
340 x 425	90	98	142	162	431	1365	232015	132	105	21 x M20	690
360 x 455	110	118	166	188	461	1433	257988	107	84	18 x M22	930
380 x 475	110	118	166	188	481	1672	317711	118	94	21 x M22	930
400 x 495	110	118	166	188	501	1672	334433	123	100	21 x M22	930

FK-06

Ordering code sample
FK-06 dxD 19x47

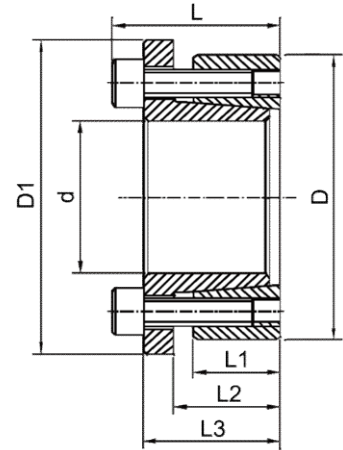

Size(mm)	Dimension (mm)					Rated Load		Surface Pressure		Tightening Screws	
	d x D	L1	L2	L3	L	D1	Axial KN	Torque N.m	Shaft N/mm2	Hub N/mm2	DIN912 12.9 N°x Type
19 x 47	17	22	28	34	56	26	243	234	94	5 x M6	17
20 x 47	17	22	28	34	56	26	256	222	94	5 x M6	17
22 x 47	17	22	28	34	56	26	282	202	94	5 x M6	17
24 x 50	17	22	28	34	59	31	368	222	106	6 x M6	17
25 x 50	17	22	28	34	59	31	383	213	106	6 x M6	17
28 x 55	17	22	28	34	64	31	429	190	97	6 x M6	17
30 x 55	17	22	28	34	64	31	460	177	97	6 x M6	17
32 x 60	17	22	28	34	69	41	655	222	118	8 x M6	17
35 x 60	17	22	28	34	69	41	716	203	118	8 x M6	17
38 x 65	17	22	28	34	74	41	778	187	109	8 x M6	17
40 x 65	17	22	28	34	74	41	819	178	109	8 x M6	17
42 x 75	20	25	33	41	84	65	1361	227	127	7 x M8	41
45 x 75	20	25	33	41	84	65	1458	212	127	7 x M8	41
50 x 80	20	25	33	41	89	65	1620	191	119	7 x M8	41
55 x 85	20	25	33	41	94	74	2037	199	129	8 x M8	41
60 x 90	20	25	33	41	99	74	2223	182	121	8 x M8	41
65 x 95	20	25	33	41	104	83	2710	189	129	9 x M8	41
70 x 110	24	30	40	50	119	120	4203	211	134	8 x M10	83
75 x 115	24	30	40	50	124	120	4754	197	128	8 x M10	83
80 x 120	24	30	40	50	129	120	4804	184	123	8 x M10	83
85 x 125	24	30	40	50	134	135	5742	195	133	9 x M10	83
90 x 130	24	30	40	50	139	135	6080	184	128	9 x M10	83
95 x 135	24	30	40	50	144	150	7131	194	137	10 x M10	83
100 x 145	26	32	44	56	154	175	8732	198	137	8 x M12	145
110 x 155	26	32	44	56	164	175	9605	180	128	8 x M12	145
120 x 165	26	32	44	56	174	196	11787	186	135	9 x M12	145
130 x 180	34	40	54	68	189	262	17024	175	126	12 x M12	145
140 x 190	34	40	54	68	199	267	18703	166	122	9 x M14	230
150 x 200	34	40	54	68	209	297	22259	172	129	10 x M14	230

FK-06

Ordering code sample
FK-06 dxD 160x210

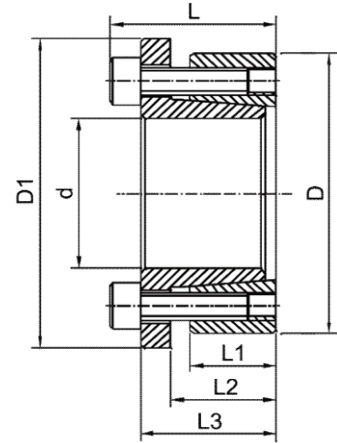

Size(mm)	Dimension (mm)					Rated Load		Surface Pressure		Tightening Screws	
	d x D	L1	L2	L3	L	D1	Axial KN	Torque N.m	Shaft N/mm2	Hub N/mm2	DIN912 12.9 N°x Type
160 x 210	34	40	54	68	219	326	26119	177	135	11 x M14	230
170 x 225	44	50	64	78	234	356	30276	140	106	12 x M14	230
180 x 235	44	50	64	78	244	356	32057	133	102	12 x M14	230
190 x 250	44	50	64	78	259	445	42302	157	119	15 x M14	230
200 x 260	44	50	64	78	269	445	44528	149	115	15 x M14	230
220 x 285	50	56	75	91	295	481	52902	129	100	12 x M16	355
240 x 305	50	56	75	91	315	601	72135	148	116	15 x M16	355
260 x 325	50	56	75	91	335	641	83370	145	116	16 x M16	355
280 x 355	60	66	87	105	365	803	112463	141	111	16 x M18	500
300 x 375	60	66	87	105	385	904	135562	148	118	18 x M18	500
320 x 405	74	81	101	121	414	1234	197493	140	110	18 x M20	690
340 x 425	74	81	101	121	434	1440	244816	153	123	21 x M20	690
360 x 455	86	94	116	138	464	1512	272218	131	104	18 x M22	930
380 x 475	86	94	116	138	484	1764	335239	145	116	21 x M22	930
400 x 495	86	94	116	138	504	1764	352884	137	111	21 x M22	930

FK-07

Ordering code sample
FK-07 dxD 20x47

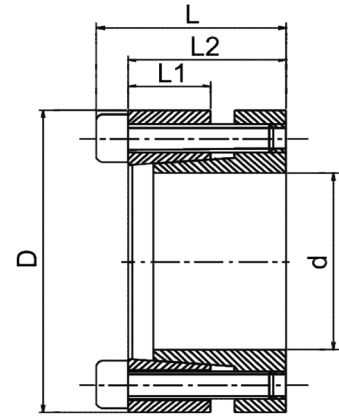

Size(mm)	Dimension (mm)			Rated Load		Surface Pressure		Tightening Screws	
	d x D	L1	L2	L	Axial KN	Torque N.m	Shaft N/mm ²	Hub N/mm ²	DIN912 12.9 N°x Type
20 x 47	14	28	34	29	294	328	139	5 x M6	14
22 x 47	14	28	34	29	323	298	139	5 x M6	14
24 x 50	14	28	34	38	455	353	169	6 x M6	14
25 x 50	14	28	34	38	474	338	169	6 x M6	14
30 x 55	14	28	34	38	569	282	154	6 x M6	14
35 x 60	14	28	34	51	885	322	188	8 x M6	14
38 x 65	14	28	34	51	961	297	174	8 x M6	14
40 x 65	14	28	34	51	1012	282	174	8 x M6	14
42 x 75	18	35	43	76	1594	313	176	7 x M8	32
45 x 75	18	35	43	76	1707	293	176	7 x M8	32
50 x 80	18	35	43	76	1897	263	165	7 x M8	32
55 x 85	18	35	43	87	2387	274	177	8 x M8	32
60 x 90	18	35	43	87	2604	251	167	8 x M8	32
65 x 95	18	35	43	98	3172	260	178	9 x M8	32
70 x 110	24	46	56	141	4937	262	167	8 x M10	65

FK-08

Ordering code sample
FK-08 dxD 14x55

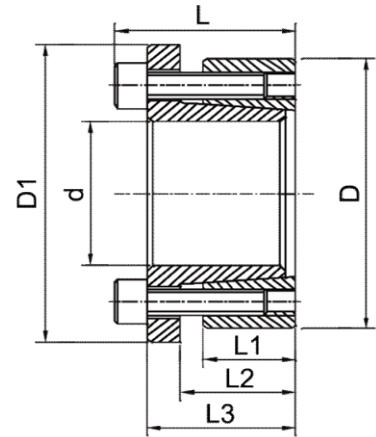

Size(mm)	Dimension (mm)					Rated Load		Surface Pressure		Tightening Screws	
	d x D	L1	L2	L3	L	D1	Axial KN	Torque N.m	Shaft N/mm2	Hub N/mm2	DIN912 12.9 N°x Type
14 x 55	17	22	30	38	62	37	259	415	106	4 x M8	41
16 x 55	17	22	30	38	62	37	296	363	106	4 x M8	41
18 x 55	17	22	30	38	62	37	333	357	117	4 x M8	41
19 x 55	17	22	30	38	62	37	352	338	117	4 x M8	41
20 x 55	17	22	30	38	62	37	370	321	117	4 x M8	41
22 x 55	17	22	30	38	62	37	407	292	117	4 x M8	41
24 x 55	17	22	30	38	62	37	445	268	117	4 x M8	41
25 x 55	17	22	30	38	62	37	463	257	117	4 x M8	41
28 x 55	17	22	30	38	62	37	519	229	117	4 x M8	41
30 x 55	17	22	30	38	62	37	556	214	117	4 x M8	41
24 x 65	17	22	30	38	72	46	556	335	124	5 x M8	41
25 x 65	17	22	30	38	72	46	579	321	124	5 x M8	41
28 x 65	17	22	30	38	72	46	649	287	124	5 x M8	41
30 x 65	17	22	30	38	72	46	695	268	124	5 x M8	41
32 x 65	17	22	30	38	72	46	741	251	124	5 x M8	41
35 x 65	17	22	30	38	72	46	811	230	124	5 x M8	41
38 x 65	17	22	30	38	72	46	917	211	124	5 x M8	41
40 x 65	17	22	30	38	72	46	966	201	124	5 x M8	41
30 x 80	20	25	33	41	87	65	972	318	119	7 x M8	41
32 x 80	20	25	33	41	87	65	1037	299	119	7 x M8	41
35 x 80	20	25	33	41	87	65	1134	273	119	7 x M8	41
38 x 80	20	25	33	41	87	65	1231	251	119	7 x M8	41
40 x 80	20	25	33	41	87	65	1296	239	119	7 x M8	41
42 x 80	20	25	33	41	87	65	1361	227	119	7 x M8	41
45 x 80	20	25	33	41	87	65	1458	212	119	7 x M8	41
48 x 80	20	25	33	41	87	65	1555	199	119	7 x M8	41
50 x 80	20	25	33	41	87	65	1620	191	119	7 x M8	41

FK-09

Ordering code sample
FK-09 dxD 100x145

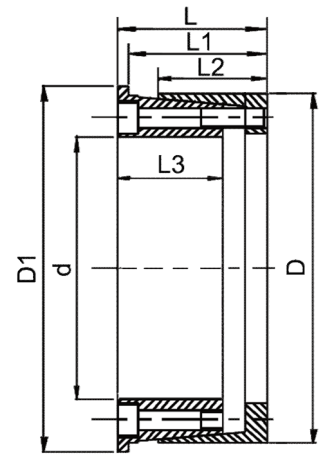

Size(mm)	Dimension (mm)					Rated Load		Surface Pressure		Tightening Screws	
	d x D	L1	L2	L3	L	D1	Axial KN	Torque N.m	Shaft N/mm ²	Hub N/mm ²	DIN912 12.9 N°x Type
100 x 145	68.5	61	54	75	154	192	9600	102	70	8 x M12	145
110 x 155	68.5	61	54	75	164	191	10500	93	66	8 x M12	145
120 x 165	68.5	61	54	75	174	216	13000	96	70	9 x M12	145
130 x 180	76	68	63	84	189	287	17800	100	78	12 x M12	145
140 x 190	76	68	63	84	199	287	20200	94	69	12 x M12	145
150 x 200	76	68	63	84	209	287	21600	88	66	12 x M12	145
160 x 210	76	68	63	84	219	360	28800	101	77	15 x M12	145
170 x 225	76	68	63	84	234	383	32600	101	76	16 x M12	145
180 x 235	76	68	63	84	244	431	38800	108	82	18 x M12	145
190 x 250	86	77	69	94	259	493	46800	106	80	15 x M14	230
200 x 260	86	77	69	94	269	526	52800	100	82	16 x M14	230
220 x 285	86	77	69	94	294	640	70000	119	92	14 x M16	355
240 x 305	103	93	86	112	314	731	88000	96	75	16 x M16	355
260 x 325	103	93	86	112	334	822	107000	103	82	18 x M16	355
280 x 355	109	99	94	120	334	910	128000	96	75	20 x M16	355
300 x 375	109	99	94	120	384	1000	151000	99	79	22 x M16	355
320 x 405	131	121	109	142	414	1280	206000	101	80	18 x M20	690
340 x 425	131	121	109	142	434	1420	242000	106	85	20 x M20	690
360 x 455	148	137	120	159	464	1770	319000	113	89	20 x M22	930
380 x 475	148	137	120	159	484	1770	337000	109	87	20 x M22	930
400 x 485	148	137	120	159	504	1770	355000	101	83	20 x M22	930
420 x 515	148	137	120	159	524	1980	410000	107	87	22 x M22	930

FK-10

Ordering code sample
FK-10 dxD 10x20

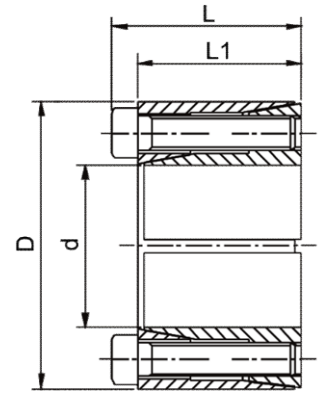

Size(mm)	Dimension (mm)		Rated Load		Surface Pressure		Tightening Screws	
	d x D	L1	L	Axial KN	Torque N.m	Shaft N/mm2	Hub N/mm2	DIN912 12.9 N°x Type
10 x 20	13	15.5	3.8	19	89	45	4 x M2.5	1.2
11 x 22	13	15.5	3.8	21	81	41	4 x M2.5	1.2
12 x 22	13	15.5	3.8	23	75	41	4 x M2.5	1.2
14 x 26	17	20	5.5	39	71	38	4 x M3	2.1
15 x 28	17	20	5.5	42	66	35	4 x M3	2.1
16 x 32	17	21	9.6	77	107	54	4 x M4	4.9
17 x 35	21	25	9.6	82	81	40	4 x M4	4.9
18 x 35	21	25	9.6	87	77	40	4 x M4	4.9
19 x 35	21	25	9.6	91	73	40	4 x M4	4.9
20 x 38	21	26	15.7	157	113	60	4 x M5	10
22 x 40	21	26	15.7	173	103	57	4 x M5	10
24 x 47	26	32	22.3	268	110	56	4 x M6	17
25 x 47	26	32	22.3	279	105	56	4 x M6	17
28 x 50	26	32	33.5	468	141	79	6 x M6	17
30 x 55	26	32	33.5	502	132	72	6 x M6	17
32 x 55	26	32	33.5	535	123	72	6 x M6	17
35 x 60	31	37	44.6	781	125	73	8 x M6	17
38 x 65	31	37	44.6	848	115	67	8 x M6	17
40 x 65	31	37	44.6	892	110	67	8 x M6	17
42 x 75	36	44	60.6	1272	122	68	6 x M8	41
45 x 75	36	44	60.6	1363	113	68	6 x M8	41
48 x 80	36	44	60.8	1938	142	85	8 x M8	41
50 x 80	36	44	60.8	2019	136	85	8 x M8	41

FK-11

Ordering code sample
FK-11 dxD 25x55

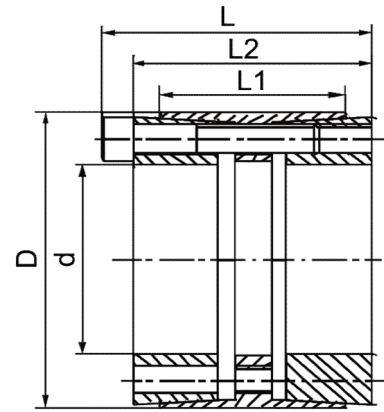

Size(mm)	Dimension (mm)			Rated Load		Surface Pressure		Tightening Screws	
	d x D	L1	L2	L	Axial KN	Torque N.m	Shaft N/mm2	Hub N/mm2	DIN912 12.9 N°x Type
25 x 55	32	40	46	64	799	314	107	6 x M6	17
28 x 55	32	40	46	64	895	281	107	6 x M6	17
30 x 55	32	40	46	64	959	262	107	6 x M6	17
35 x 60	44	54	60	75	1306	185	83	7 x M6	17
38 x 75	44	54	62	135	2567	308	121	7 x M8	41
40 x 75	44	54	62	135	2702	293	121	7 x M8	41
42 x 75	44	54	62	135	2837	279	121	7 x M8	41
45 x 75	44	54	62	135	3040	260	121	7 x M8	41
48 x 80	56	64	72	154	3707	216	102	8 x M8	41
50 x 80	56	64	72	154	3861	207	102	8 x M8	41
55 x 85	56	64	72	174	4779	212	108	9 x M8	41
60 x 90	56	64	72	193	5793	216	113	10 x M8	41
65 x 95	56	64	72	193	6276	199	107	10 x M8	41
70 x 110	70	78	88	313	10951	235	120	10 x M10	83
75 x 115	70	78	88	313	11733	220	115	10 x M10	83
80 x 120	70	78	88	344	13768	227	121	11 x M10	83
85 x 125	70	78	88	376	15959	233	127	12 x M10	83
90 x 130	70	78	88	376	16898	220	122	12 x M10	83
95 x 135	70	78	88	376	17837	208	117	12 x M10	83
100 x 145	90	100	112	501	25029	211	113	11 x M12	145
110 x 155	90	100	112	546	30039	209	115	12 x M12	145
120 x 165	90	100	112	637	38226	224	127	14 x M12	145
130 x 180	104	116	130	743	48270	201	117	12 x M14	230
140 x 190	104	116	130	866	60654	217	129	14 x M14	230
150 x 200	104	116	130	928	69628	217	132	15 x M14	230
160 x 210	104	116	130	990	79220	217	134	16 x M14	230
170 x 225	134	148	164	1186	100851	206	116	14 x M16	360
180 x 235	134	148	164	1271	114414	208	119	15 x M16	360
190 x 250	134	148	164	1356	128814	210	119	16 x M16	360

FK-11

Ordering code sample
FK-11 dxD 220x285

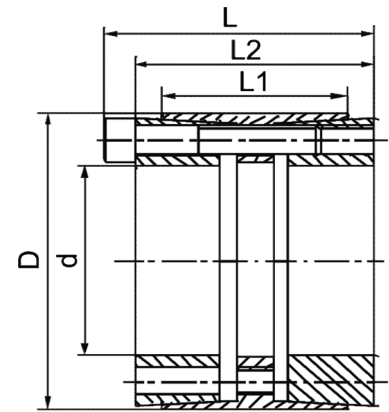

Size(mm)	Dimension (mm)			Rated Load		Surface Pressure		Tightening Screws	
	d x D	L1	L2	L	Axial KN	Torque N.m	Shaft N/mm ²	Hub N/mm ²	DIN912 12.9 N°x Type
200 x 260	134	148	164	1356	135594	200	115	16 x M16	360
220 x 285	134	148	164	1526	167805	204	118	18 x M16	360
240 x 305	134	150	166	1626	195100	182	131	20 x M16	360
260 x 325	134	150	166	1707	221930	176	129	21 x M16	360
280 x 355	165	177	197	2244	314194	179	131	18 x M20	690
300 x 375	165	177	197	2494	374042	186	138	20 x M20	690
320 x 405	165	177	197	2618	418936	183	134	21 x M20	690
340 x 425	165	177	197	2743	466307	180	134	22 x M20	690
360 x 455	190	203	225	3208	577426	173	130	21 x M22	930
380 x 475	190	203	225	3361	638541	172	130	22 x M22	930
400 x 495	190	203	225	3666	733255	178	137	24 x M22	930
420 x 515	190	203	225	3666	769918	169	131	24 x M22	930
440 x 535	190	203	225	3666	807670	162	130	24 x M22	930
460 x 555	190	203	225	3666	844390	155	128	24 x M22	930
480 x 575	190	203	225	4275	1027650	173	145	28 x M22	930
500 x 595	190	203	225	4275	1071000	166	140	28 x M22	930
520 x 615	190	203	225	4600	1193400	171	144	30 x M22	930
540 x 635	190	203	225	4600	1239300	164	139	30 x M22	930
560 x 655	190	203	225	4896	1371050	169	144	32 x M22	930
580 x 675	190	203	225	4896	1419500	163	141	32 x M22	930
600 x 695	190	203	225	5040	1514700	163	141	33 x M22	930

FK-12

Ordering code sample
FK-12 dxD 18x40

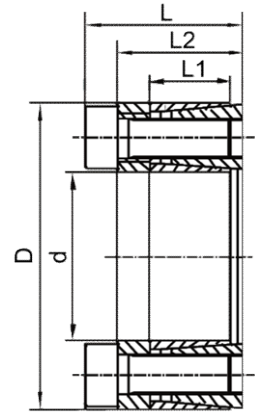

Size(mm)	Dimension (mm)			Rated Load		Surface Pressure		Tightening Screws	
	d x D	L1	L2	L	Axial KN	Torque N.m	Shaft N/mm2	Hub N/mm2	DIN912 12.9 N°x Type
18 x 40	12	18.5	24.5	23	207	204	92	6 x M6	15
19 x 41	12	18.5	24.5	23	219	193	89	6 x M6	15
20 x 42	12	18.5	24.5	23	230	183	87	6 x M6	15
24 x 46	12	18.5	24.5	23	276	153	80	6 x M6	15
25 x 47	12	18.5	24.5	31	383	196	104	8 x M6	15
28 x 50	12	18.5	24.5	31	429	175	98	8 x M6	15
30 x 52	12	18.5	24.5	31	460	163	94	8 x M6	15
35 x 57	15	22	28	46	805	176	108	12 x M6	15
38 x 60	15	22	28	46	874	162	103	12 x M6	15
40 x 62	15	22	28	46	920	154	99	12 x M6	15
42 x 70	18	28	36	81	1692	202	121	12 x M8	35
45 x 73	18	28	36	81	1813	189	116	12 x M8	35
48 x 76	18	28	36	81	1934	177	112	12 x M8	35
50 x 78	18	28	36	81	2014	170	109	12 x M8	35
55 x 83	18	28	36	107	2952	206	136	16 x M8	35
60 x 88	18	28	36	107	3221	188	128	16 x M8	35
70 x 105	22	35	45	129	4531	155	103	12 x M10	70
80 x 115	22	35	45	172	6877	181	126	16 x M10	70

FK-13

Ordering code sample
FK-13 dxD 15x45

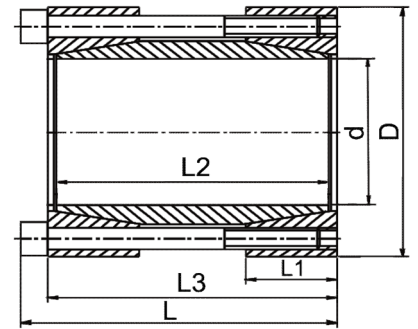

Size(mm)	Dimension (mm)				Rated Load		Surface Pressure	Tightening Screws	
	d x D	L1	L2	L3	L	Axial KN	Torque N.m	Shaft N/mm2	DIN912 12.9 N°x Type Tightening Torque N.m
15 x 45	16	44	50	56	21	158	188	4 x M6	17
16 x 50	16	44	50	56	21	168	176	4 x M6	17
17 x 50	16	44	50	56	21	179	166	4 x M6	17
18 x 50	16	44	50	56	21	190	157	4 x M6	17
19 x 50	16	44	50	56	21	200	149	4 x M6	17
20 x 50	16	44	50	56	21	211	141	4 x M6	17
24 x 55	18.5	54	60	66	32	378	144	6 x M6	17
25 x 55	18.5	54	60	66	32	394	138	6 x M6	17
28 x 60	18.5	54	60	66	32	442	123	6 x M6	17
30 x 60	18.5	54	60	66	32	473	115	6 x M6	17
32 x 63	18.5	54	60	66	32	505	108	6 x M6	17
35 x 75	22	67	75	83	39	682	98	4 x M8	42
38 x 75	22	67	75	83	39	741	90	4 x M8	42
40 x 75	22	67	75	83	39	780	86	4 x M8	42
42 x 78	22	67	75	83	39	819	82	4 x M8	42
45 x 85	24.5	76	85	93	59	1317	101	6 x M8	42
48 x 90	24.5	76	85	93	59	1405	95	6 x M8	42
50 x 90	24.5	76	85	93	59	1463	91	6 x M8	42
55 x 94	24.5	76	85	93	78	2147	110	8 x M8	42
60 x 100	24.5	76	85	93	78	2343	101	8 x M8	42
65 x 105	24.5	76	85	93	78	2538	93	8 x M8	42
70 x 115	29	90	100	110	93	3239	87	6 x M10	83
75 x 120	29	90	100	110	93	3471	81	6 x M10	83

FK-14

Ordering code sample
FK-14 dxD 70x120

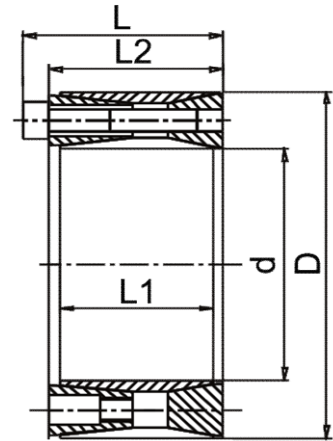

Size(mm)	Dimension (mm)			Rated Load		Surface Pressure		Tightening Screws	
	d x D	L1	L2	L	Axial KN	Torque N.m	Shaft N/mm2	Hub N/mm2	DIN912 12.9 N°x Type
70 x 120	56	62	74	197	6850	201	117	8 x M12	145
80 x 130	56	62	74	291	11650	263	162	12 x M12	145
90 x 140	56	62	74	290	13000	234	150	12 x M12	145
100 x 160	74	80	94	389	19700	213	133	12 x M14	230
110 x 170	74	80	94	483	26600	242	157	14 x M14	230
120 x 180	74	80	94	483	28900	222	148	15 x M14	230
130 x 190	74	80	94	483	31200	205	140	15 x M14	230
140 x 200	74	80	94	574	40200	227	159	17 x M14	230
150 x 210	74	80	94	574	42900	212	152	18 x M14	230
160 x 230	88	94	110	800	64000	227	158	17 x M16	355
170 x 240	88	94	110	800	67800	214	152	18 x M16	355
180 x 250	88	94	110	923	83000	235	170	20 x M16	355
190 x 260	88	94	110	923	88000	223	163	21 x M16	355
200 x 270	88	94	110	1050	105000	242	179	23 x M16	355
220 x 300	110	116	134	1120	123000	189	138	21 x M18	485
240 x 320	110	116	134	1280	153000	198	148	24 x M18	485
250 x 330	110	116	134	1282	160200	205	157	27 x M18	485
260 x 340	110	116	134	1430	186000	205	157	27 x M18	485
280 x 370	130	136	156	1650	230000	192	145	24 x M20	690
300 x 390	130	136	156	1650	245000	179	138	24 x M20	690

FK-15

Ordering code sample
FK-15 dxD 100x145

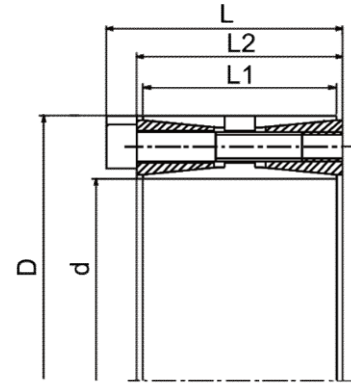

Size(mm)	Dimension (mm)			Rated Load		Surface Pressure		Tightening Screws	
	d x D	L1	L2	L	Axial KN	Torque N.m	Shaft N/mm2	Hub N/mm2	DIN912 12.9 N°x Type
100 x 145	60	65	77	288	14400	192	132	10 x M12	145
110 x 155	60	65	77	288	15850	175	123	10 x M12	145
120 x 165	60	65	77	346	20750	192	139	12 x M12	145
130 x 180	68	74	86	433	28100	193	139	15 x M12	145
140 x 190	68	74	86	519	36300	214	157	18 x M12	145
150 x 200	68	74	86	519	39000	200	150	18 x M12	145
160 x 210	68	74	86	606	48500	219	167	21 x M12	145
170 x 225	75	81	95	712	60600	215	162	18 x M14	230
180 x 235	75	81	95	712	64100	203	155	18 x M14	230
190 x 250	88	94	108	792	75200	178	135	20 x M14	230
200 x 260	88	94	108	950	95000	203	156	24 x M14	230
210 x 275	98	104	120	970	102000	187	142	18 x M16	355
220 x 285	98	104	120	990	109000	183	141	18 x M16	355
240 x 305	98	104	120	1318	153382	222	176	24 x M16	355
250 x 315	98	104	120	1340	159773	215	170	24 x M16	355
260 x 325	98	104	120	1370	173085	215	172	25 x M16	355
280 x 355	120	126	144	1590	217622	188	149	24 x M18	485
300 x 375	120	126	144	1650	242887	183	146	25 x M18	485
320 x 405	135	142	162	2140	332001	192	152	25 x M20	690
340 x 425	135	142	162	2140	352751	181	144	25 x M20	690
360 x 455	158	165	187	2670	455557	175	139	25 x M22	930
380 x 475	158	165	187	2670	480866	166	133	25 x M22	930
400 x 495	158	165	187	2670	506174	158	128	25 x M22	930
420 x 515	158	165	187	3200	637762	181	147	30 x M22	930
450 x 555	172	180	204	3700	809627	175	142	30 x M24	1200
480 x 585	172	180	204	3950	921171	175	143	32 x M24	1200
500 x 605	172	180	204	3950	959553	168	139	32 x M24	1200
530 x 640	190	200	227	4320	1129002	157	130	30 x M27	1600
560 x 670	190	200	227	4320	1192908	148	124	30 x M27	1600
600 x 710	190	200	227	4610	1363327	147	124	32 x M27	1600

FK-16

Ordering code sample
FK-16 dxD 30x60

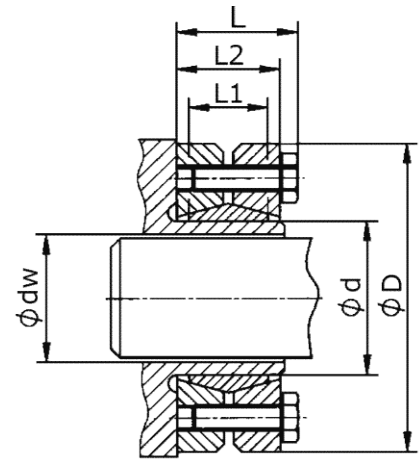

Size(mm)	Shaft	Outer	Torque	Dimensions				Surface Pressure	Screws	
d	dw	D	N.m	L	L1	L2	Fitting Tolerance max.mm	Shaft N/mm ²	DIN912 12.9 N°x Type	TA N.m
30	24	60	350	25.5	16	22	0.017	159	7 x M5	7
	25		400					172		
	26		470					184		
36	28	72	730	27.5	18	23.5	0.032	232	5 x M6	5
	30		860					240		
	31		880					250		
38	29	72	710	27.5	18	23.5	0.032	198	6 x M6	6
	30		735					205		
	31		760					211		
40	30	72	770	27.5	18	23.5	0.032	216	6 x M6	6
	31		800					223		
	32		825					230		
44	32	80	1200	29.5	20	25.5	0.032	225	7 x M6	7
	35		1400					235		
	36		1500					244		
48	36	80	1350	29.5	20	25.5	0.032	222	7 x M6	7
	38		1450					236		
	40		1530					248		
50	38	90	1500	31.5	22	28	0.032	204	8 x M6	12
	40		1800					219		
	42		2100					232		
55	42	100	1700	34.5	23	31	0.032	176	8 x M6	12
	45		2100					193		
	48		2600					210		
62	48	110	2700	34.5	23	31	0.048	213	10 x M6	12
	50		3000					218		
	52		3200					222		

FK-16

Ordering code sample
FK-16 dxD 68x115

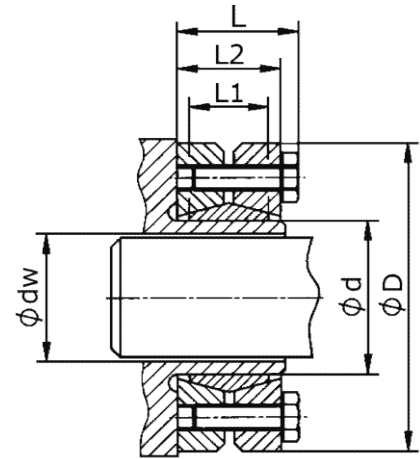

Size(mm)	Shaft	Outer	Torque	Dimensions				Surface Pressure	Screws	
d	dw	D	N.m	L	L1	L2	Fitting Tolerance max.mm	Shaft N/mm ²	DIN912 12.9 N°x Type	TA N.m
68	50	115	2500	34.5	23	30.5	0.048	184	10 x M6	12
	55		3100					188		
	60		4100					212		
75	55	138	3500	37.8	25	32.5	0.048	199	7 x M8	30
	60		4700					221		
	65		6000					241		
80	60	145	4100	37.8	25	32.5	0.048	192	7 x M8	30
	65		5200					211		
	70		6600					228		
85	60	155	6900	44.3	30	39	0.048	179	10 x M8	30
	65		7500					194		
	70		8150					209		
90	65	155	6200	44.3	30	39	0.048	206	10 x M8	30
	70		7700					222		
	75		9400					236		
95	65	170	7200	49.3	34	44	0.048	197	12 x M8	30
	70		7800					213		
	75		8300					228		
100	70	170	7600	49.3	34	44	0.048	194	12 x M8	30
	75		9300					207		
	80		11300					220		
110	75	185	9100	56.4	39	50	0.048	176	9 x M10	59
	80		11000					188		
	85		12200					183		
115	80	185	10400	56.4	39	50	0.048	177	9 x M10	59
	90		11700					199		
	95		12400					210		

FK-16

Ordering code sample
FK-16 dxD 125x215

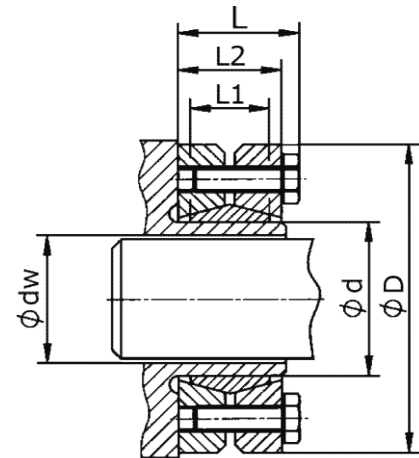

Size(mm)	Shaft	Outer	Torque	Dimensions				Surface Pressure	Screws	
d	dw	D	N.m	L	L1	L2	Fitting Tolerance max.mm	Shaft N/mm ²	DIN912 12.9 N°x Type	TA N.m
125	85	215	13300	60.4	42	54.0	0.069	186	12 x M10	59
	90		15800					198		
	95		18600					209		
140	95	230	18600	68	46	60.5	0.070	190	10 x M12	100
	100		21600					199		
	105		24900					208		
155	105	265	25400	72	50	64.5	0.070	195	12 x M12	100
	110		29000					203		
	115		32800					211		
165	115	290	38900	81	56	71	0.070	223	8 x M16	250
	120		43600					230		
	125		47600					231		
175	125	300	42900	81	56	71	0.080	208	8 x M16	250
	130		47800					215		
	135		53100					221		
185	135	330	60000	96	71	86	0.090	197	10 x M16	250
	140		66400					202		
	145		73100					208		
195	140	350	75600	96	71	86	0.090	231	12 x M16	250
	150		90600					241		
	155		98700					245		
200	150	350	87000	96	71	86	0.090	231	12 x M16	250
	155		94800					236		
	160		103000					240		

FK-17

Ordering code sample
FK-17 dxD 24x50

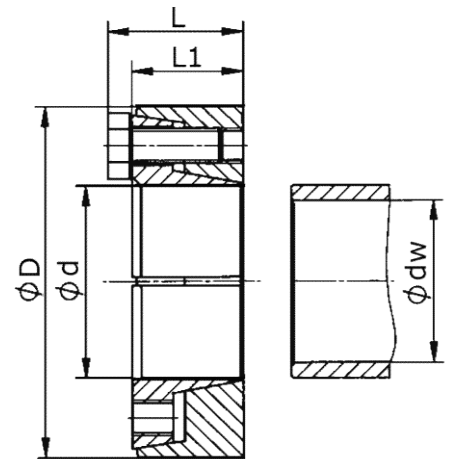

Size(mm)	Shaft	Outer	Torque	Dimensions			Surface Pressure	Screws	
d	dw	D	N.m	L	L1	Fitting Tolerance max.mm	Shaft N/mm ²	DIN912 12.9 N°x Type	TA N.m
24	19	50	172	22	18	0.017	145	5 x M6	12
	20		218				165		
	21		267				184		
30	24	60	297	24	20	0.017	137	6 x M6	12
	25		352				150		
	26		412				162		
36	28	72	563	27.3	22	0.017	169	5 x M8	30
	30		714				187		
	31		722				177		
44	34	80	734	29.3	24	0.032	135	6 x M8	30
	35		831				144		
	36		933				153		
50	38	90	1230	31.3	26	0.032	166	8 x M8	30
	40		1490				180		
	42		1760				193		
55	42	100	1640	34.3	29	0.032	172	8 x M8	30
	45		2080				190		
	48		2560				206		
62	48	110	1940	34.3	29	0.032	156	9 x M8	30
	50		2230				165		
	52		2340				160		
68	55	115	1810	34.3	29	0.048	134	9 x M8	30
	60		2620				160		
	65		3590				184		
75	55	138	2770	37.4	31	0.048	156	10 x M10	59
	60		3760				178		
	65		4910				197		

FK-17

Ordering code sample
FK-17 dxD 80x145

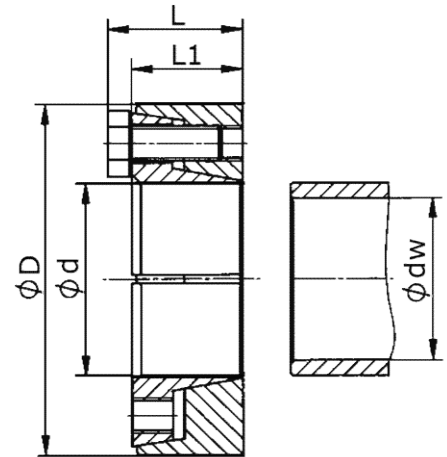

Size(mm)	Shaft	Outer	Torque	Dimensions			Surface Pressure	Screws	
d	dw	D	N.m	L	L1	Fitting Tolerance max.mm	Shaft N/mm ²	DIN912 12.9 N°x Type	TA N.m
80	60	145	3200	37.4	31	0.048	151	10 x M10	59
	65		4230				170		
	70		5400				187		
90	65	155	4730	44.4	38	0.048	159	11 x M10	59
	70		6030				174		
	75		7500				189		
100	70	170	6440	49.4	43	0.048	164	14 x M10	59
	75		7990				177		
	80		9720				190		
110	75	185	8810	56.5	49	0.048	170	12 x M12	100
	80		10600				182		
	85		11700				192		
115	80	197	11200	60.5	53	0.069	177	12 x M12	100
	85		12200				170		
	90		14700				183		
120	85	197	11000	60.5	53	0.069	154	12 x M12	100
	90		13300				166		
	95		15900				178		
125	85	215	11600	60.5	53	0.069	163	14 x M12	100
	90		14000				175		
	95		16600				186		
130	85	215	10600	60.5	53	0.069	149	14 x M12	100
	90		12800				161		
	95		15300				171		
135	90	230	13000	66.8	58	0.069	148	12 x M14	160
	95		15200				159		
	100		18200				169		

FK-17

Ordering code sample
FK-17 dxD 140x230

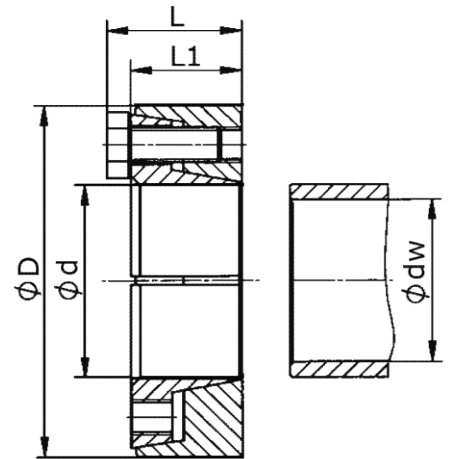

Size(mm)	Shaft	Outer	Torque	Dimensions			Surface Pressure	Screws	
d	dw	D	N.m	L	L1	Fitting Tolerance max.mm	Shaft N/mm ²	DIN912 12.9 N°x Type	TA N.m
140	95	230	14300	66.8	58	0.069	146	12 x M14	160
	100		16800				156		
	105		19600				165		
155	105	263	20900	70.8	62	0.069	161	12 x M14	160
	110		24000				169		
	115		27400				176		
165	115	290	31700	78.0	68	0.069	182	12 x M16	250
	120		35800				189		
	125		39100				190		
175	125	300	40000	78.0	68	0.079	194	12 x M16	250
	130		44700				201		
	135		49700				207		
180	135	320	56000	95.0	85	0.079	184	16 x M16	250
	140		62100				189		
	145		68500				195		
185	135	320	53100	95.0	85	0.079	174	16 x M16	250
	140		59000				180		
	145		65200				185		
200	150	340	75100	95.0	85	0.079	200	16 x M16	250
	155		82000				204		
	160		89300				209		
220	160	370	103000	115.5	103	0.079	195	16 x M20	490
	165		112000				199		
	170		121000				203		
240	170	405	125000	119.5	107	0.079	201	18 x M20	490
	180		145000				208		
	190		164000				211		